

USER MANUAL

LVTS-256100 Lithium Battery

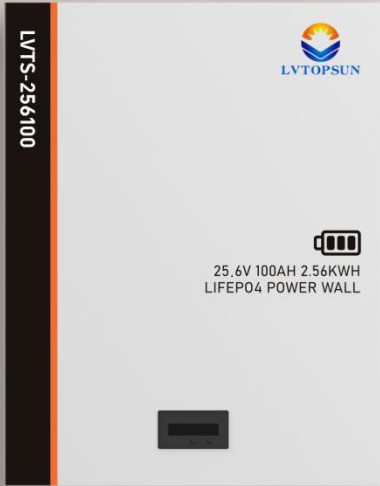



Contents

1 Product Overview	1
1.1 Appearance	1
1.1.1 Rack mounted LVTS-256100	1
1.1.2 Wall mounted LVTS-256100	1
2 Installation Guide	2
2.1 Checking Deliverables	2
2.2 Tools	3
2.3 Installation Instructions	4
2.3.1 Installation Step	4
3 Technical Specifications	8
4 Maintenance	9
4.1 Recharge Requirements During Storage	9
4.2 Recharge Requirements When Over Discharged	9



1 Product Overview

LVTS-256100 is a 25.6V 100Ah Lithium battery that can be rack mounted or wall mounted, **LVTS-256100 is not suitable for life-sustaining medical devices.**

1.1 Appearance

1.1.1 Rack mounted LVTS-256100

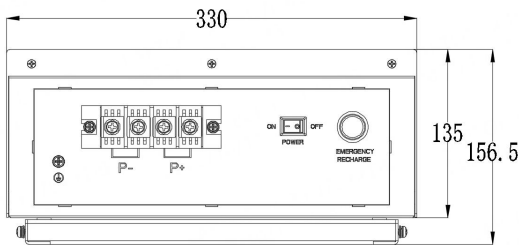

1.1.2 Wall mounted LVTS-256100

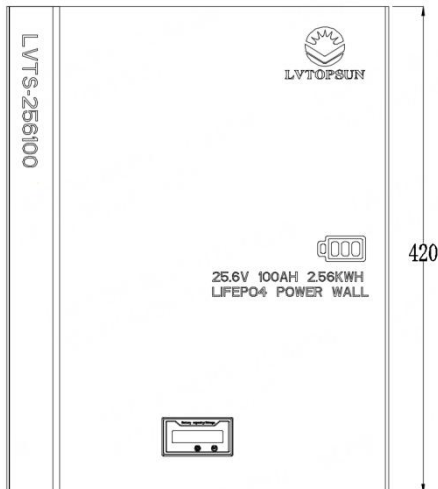







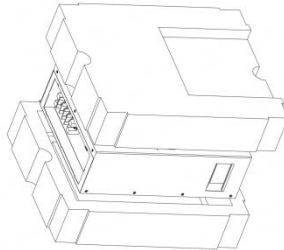
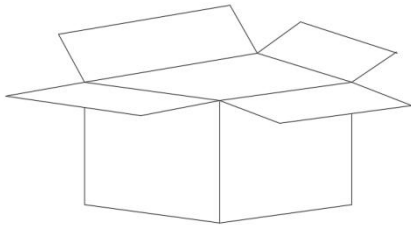

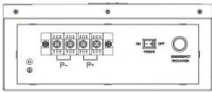
2 Installation Guide

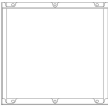
2.1 Checking Deliverables





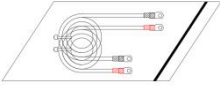



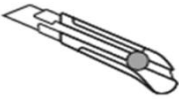

NO.	Pictures	Quantity	Description
1		1 pc	Battery
2		4 pcs	Battery hanging bolt
3		4 pcs	Battery hanger
4		1 pc	Bracket
5		4 pcs	Expansion Bolt

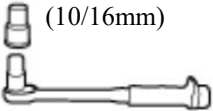

6		2 pcs	Bottom Wall Bracket Bolt
7		1 pair	Power cable
8		1 pc	Instruction book

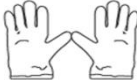
2.2 Tools

Tools			
Installation	Knife 	Measuring tape 	Socket wrench (10/16mm) 
	Hammer 	Cross Screwdriver 	Hammer drill 
Protection	ESD gloves 	Safety goggles 	Safety Shoes 



2.3 Installation Instructions

Minimum mounting distance requirement: (Wall Mounted)

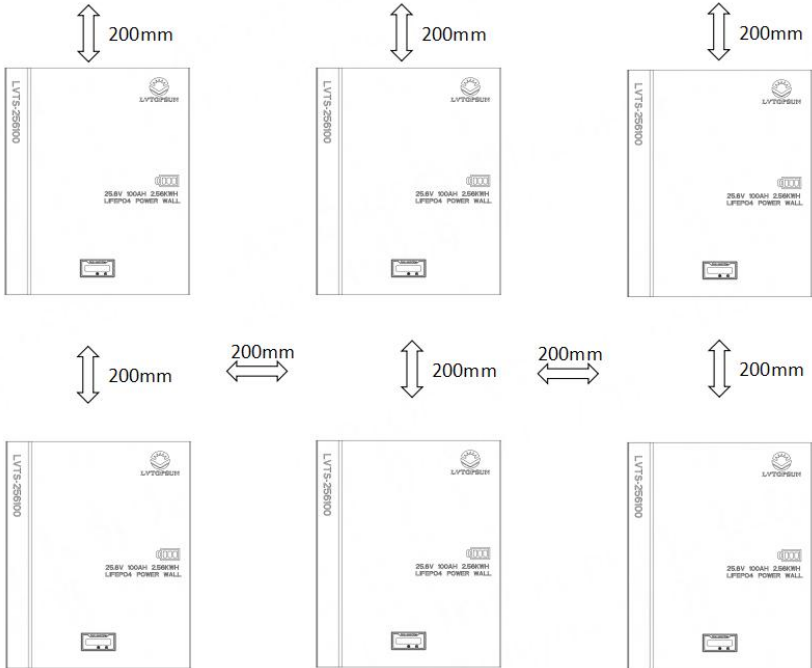

2.3.1 Installation Step

Step 1

Drill holes in the wall according to cardboard.

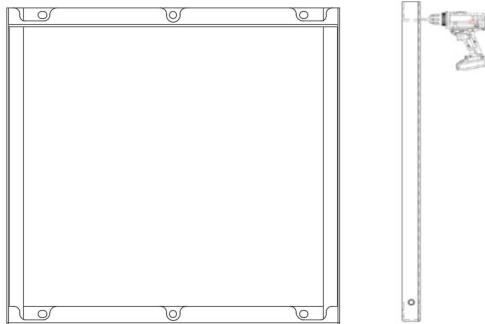



Step 2

Fix top & bottom wall brackets to the wall.

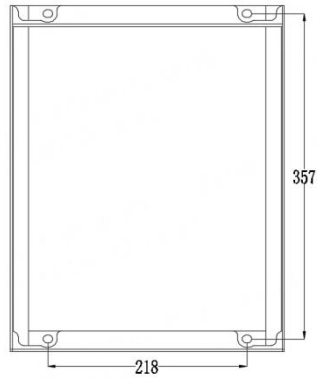

Step 3

Install the hanging bracket.

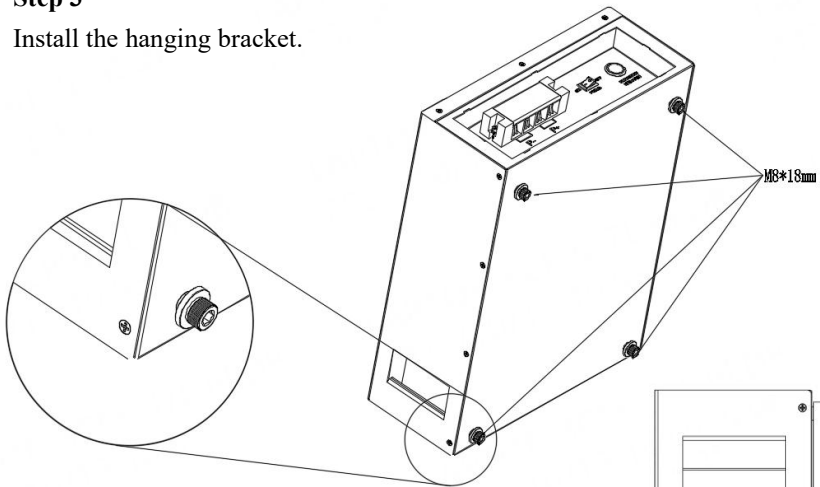

Step 4

Hang LVTS-256100 battery on wall brackets.

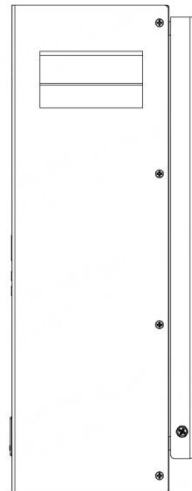



Step 5

Install 2 pcs bottom bracket bolt.

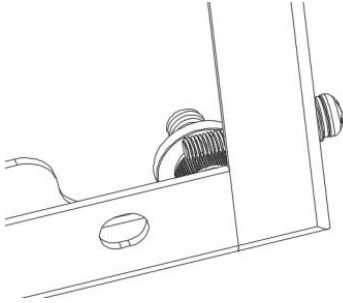

Step 6

Connect PE cable & power cable.

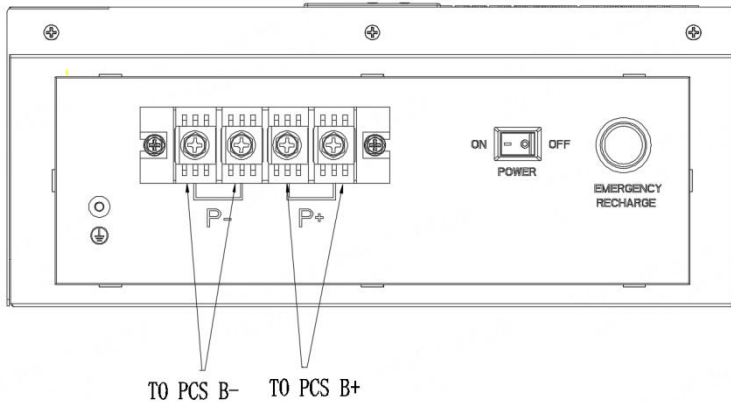
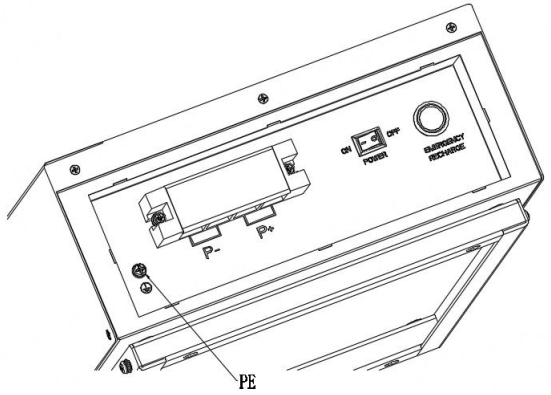



Step 7

Refer to the following diagram when multiple batteries are connected in parallel:

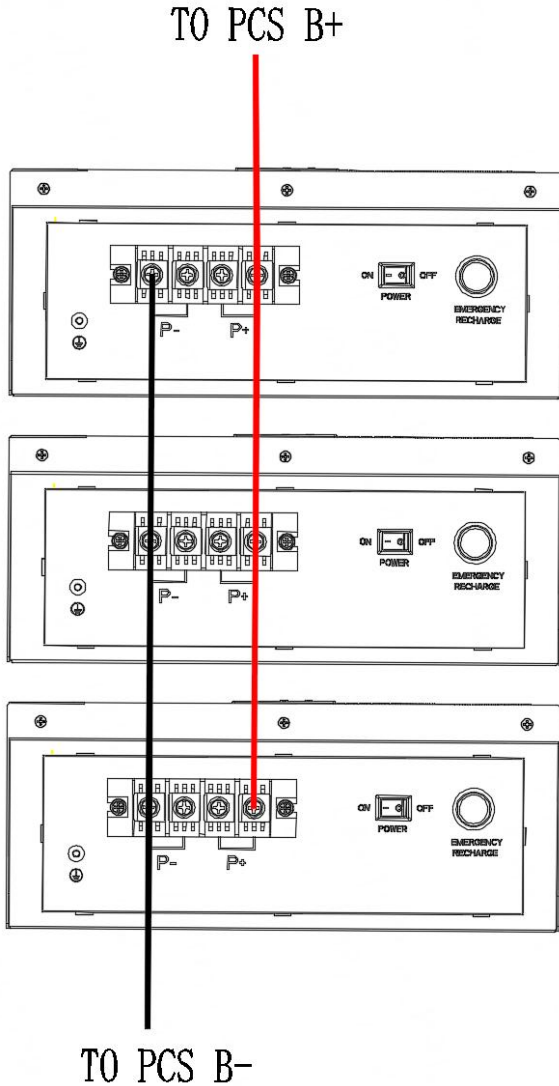



3 Technical Specifications

Basic Project		Parameter
Nominal Voltage		25.6V
Nominal Capacity		100Ah
Nominal Energy		2560Wh
Charge Voltage		28.08V
Charge Current		50A
Discharge Voltage Range		22.8V~28.08V
Discharge Current		100A
Communication Mode		/
Working Temperature	Charge	0°C~55°C
	Discharge	-20°C~55°C
Storage Temperature	Short Term (within 1 month)	-10°C~45°C
	Long Term (within 1 year)	0°C~35°C
Storage Humidity		<95% RH
Cell Type		LiFePO ₄ , Lithium Iron Phosphate
Size		H420*W330*D135(mm)
Weight		25.8KG (Wall Bracket Included)
IP Level		IP20



4 Maintenance

4.1 Recharge Requirements During Storage

Batteries should be stored in temperature between $-10^{\circ}\text{C} \sim +45^{\circ}\text{C}$, and recharged regularly according to the following table with 0.2C (20A) current to 50% SOC after long time storage.

Recharge requirement during storage

Storage Temperature	Storage Relative Humidity	Storage Time	SOC
Below -10°C	/	Not Allowed	/
$-10\sim 0^{\circ}\text{C}$	5%~70%	≤ 1 months	$30\% \leq \text{SOC} \leq 60\%$
$0\sim 25^{\circ}\text{C}$	5%~70%	≤ 12 months	$30\% \leq \text{SOC} \leq 60\%$
$25\sim 35^{\circ}\text{C}$	5%~70%	≤ 6 months	$30\% \leq \text{SOC} \leq 60\%$
$35\sim 45^{\circ}\text{C}$	5%~70%	≤ 1 months	$30\% \leq \text{SOC} \leq 60\%$
Above 45°C	/	Not Allowed	/

4.2 Recharge Requirements When Over Discharged

Please recharge over discharged (90% DOD) batteries according to the following table, otherwise over discharged battery will be damaged.

Recharge requirement when battery is over discharged

Storage Temperature	Storage Time	Note
$-10\sim 25^{\circ}\text{C}$	≤ 15 days	Battery disconnected from PCS
$25\sim 45^{\circ}\text{C}$	≤ 7 days	
$-10\sim 45^{\circ}\text{C}$	< 12 hours	Battery connected to PCS

Attention: Disposal of batteries should follow local regulations.