



# USER MANUAL

## LVTS-512300 Li Battery



## Contents

1	Product Overview .....	1
1.1	Appearance .....	1
1.2	Switch, LCD, LED & Communication Port .....	2
1.2.1	DIP Switch .....	2
1.2.2	Switch ON/OFF .....	3
1.2.3	LCD Display .....	3
1.2.4	LED Definition .....	4
1.2.5	Communication Port Definition .....	6
2	Installation Guide .....	7
2.1	Checking Deliverables .....	7
2.2	Tools .....	8
2.3	Installation Instructions .....	9
2.3.1	Installation Step .....	9
3	Technical Specifications .....	13
4	Maintenance .....	14
4.1	Recharge Requirements During Storage .....	14
4.2	Recharge Requirements When Over Discharged .....	14



# 1 Product Overview

LVTS-512300 is a 51.2V 300Ah Lithium battery that can be floor mounted.

Note: LVTS-512300 is **NOT** suitable for life-sustaining medical devices.

## 1.1 Appearance

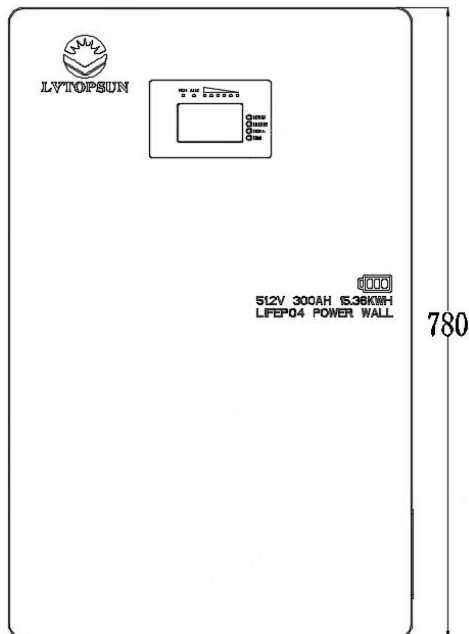
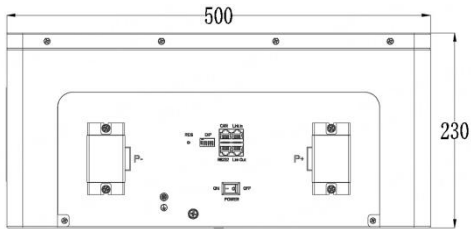



## 1.2 Switch, LCD, LED & Communication Port

### 1.2.1 DIP Switch

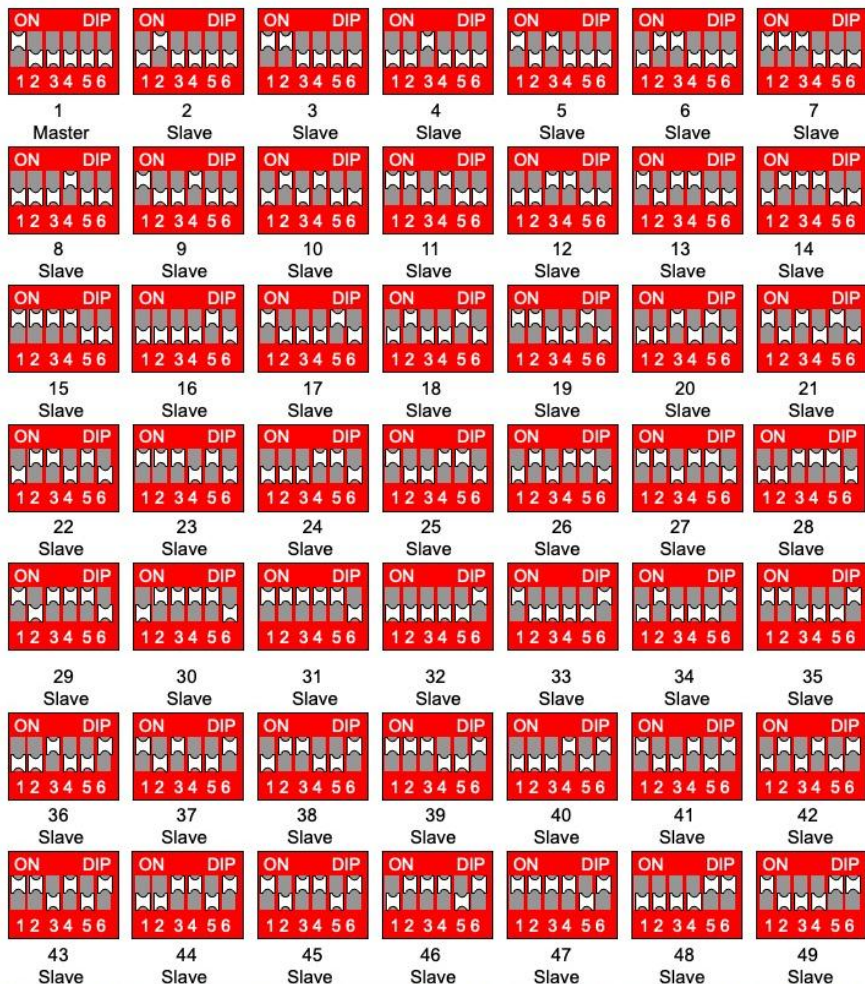

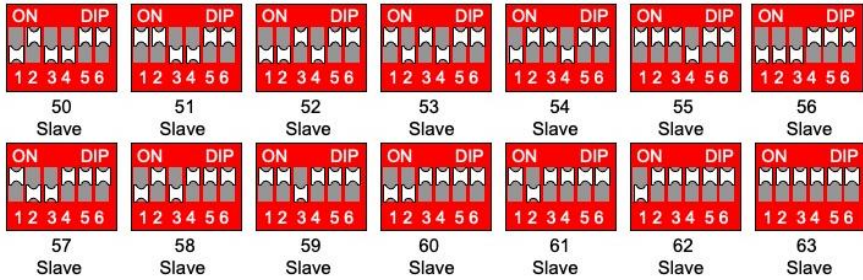

## 1.2.2 Switch ON/OFF

### 1、Switch ON

For single LVTS-512300, set DIP switch to 1, then switch ON POWER button.

For multiple LVTS-512300 connected in parallel, set DIP switch according to 1.2.1, then switch ON POWER buttons of all batteries.

### 2、Switch OFF

Switch OFF POWER button(s) of all batteries.

## 1.2.3 LCD Display

Press “MENU” button to main menu page.

Press “ESC” button to return to previous menu.

Every line is started with “>>” or “--”, “>>” is the current cursor.

Press “DOWN” button to move cursor.

If a line is ended with “>>”, you can press “ENTER” button to see more information.

If you don't press any button, LCD display will switch OFF after 1 min to save energy. You can press any button to switch ON LCD display.

---

---



## 1.2.4 LED Definition

Note: Flash 1 - 0.25s ON / 3.75s OFF

Flash 2 - 0.5s ON / 0.5s OFF

Flash 3 - 0.5s ON / 1.5s OFF

### SOC Status while charging

STATUS		CHARGE							
		L8 ●	L7 ●	L6 ●	L5 ●	L4 ●	L3 ●	L2 ●	L1 ●
SOC (%)	0~17	ON	OFF	OFF	OFF	OFF	OFF	OFF	Flash 2
	18~33			OFF	OFF	OFF	OFF	Flash 2	ON
	34~50			OFF	OFF	OFF	Flash 2	ON	ON
	51~66			OFF	OFF	Flash 2	ON	ON	ON
	67~83			OFF	Flash 2	ON	ON	ON	ON
	84~100			Flash 2	ON	ON	ON	ON	ON

### SOC Status while discharging

STATUS		DISCHARGE							
		L8 ●	L7 ●	L6 ●	L5 ●	L4 ●	L3 ●	L2 ●	L1 ●
SOC (%)	0~17	Flash 3	OFF	OFF	OFF	OFF	OFF	OFF	ON
	18~33			OFF	OFF	OFF	OFF	ON	ON
	34~50			OFF	OFF	OFF	ON	ON	ON
	51~66			OFF	OFF	ON	ON	ON	ON
	67~83			OFF	ON	ON	ON	ON	ON
	84~100			ON	ON	ON	ON	ON	ON



### Work Status

STATUS	RUN	ALM	SOC							DESCRIPTION	
	L8 ●	L7 ●	L6 ●	L5 ●	L4 ●	L3 ●	L2 ●	L1 ●			
Shutdown	OFF	OFF	OFF	OFF	OFF	OFF	OFF	OFF	OFF		
Standby	Flash 1	OFF	According to SOC								
Charge	Normal	ON	OFF	According to SOC							
	Over volt	ON	OFF	ON	ON	ON	ON	ON	ON	Switch to standby mode	
	Protection	OFF	ON	OFF	OFF	OFF	OFF	OFF	OFF	Stop charging	
Discharge	Normal	Flash 3	OFF	According to SOC							
	Under volt	OFF	OFF	OFF	OFF	OFF	OFF	OFF	OFF	Stop discharging	
	Protection	OFF	ON	OFF	OFF	OFF	OFF	OFF	OFF	Stop discharging	
Faulty	OFF	ON	OFF	OFF	OFF	OFF	OFF	OFF	OFF	Stop charging and discharging	



## 1.2.5 Communication Port Definition

### 1.2.5.1 CAN/RS485 to PCS

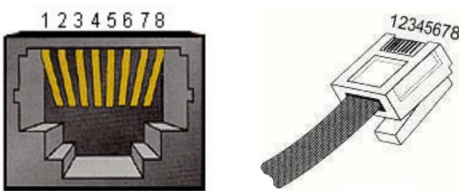
Port definitions	RJ45 Pin	Function
	1	RS485-B
	2	RS485-A
	3	GND
	4	CAN-H
	5	CAN-L
	6	NC
	7	RS485-A
	8	RS485-B

### 1.2.5.2 RS232 to PC

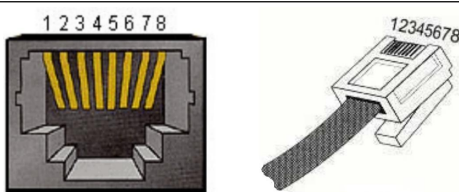
Port definitions	RJ45 Pin	Function
	1	RS232-TX
	2	GND
	3	RS232-RX
	4	NC
	5	NC
	6	NC
	7	NC
	8	NC









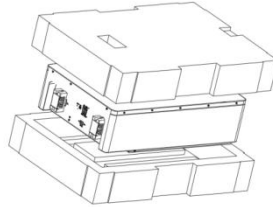
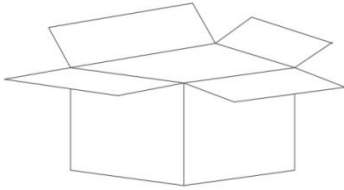

## 2 Installation Guide

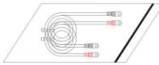
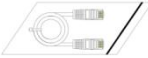
### 2.1 Checking Deliverables









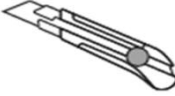

NO.	Pictures	Quantity	Description
1		1 pc	Battery
2		1 pc	cover
3		2 pcs	Cover bolt
4		1 pair	Power cable
5		1 pc	Comm cable
6		1 pc	Manual
7		5 pc	Rubber Grommet

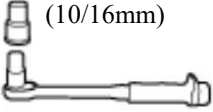

8		1 pc	Expansion Bolt
9		1 pc	Wall Connector

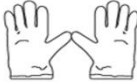
## 2.2 Tools

Tools			
Installation	Knife 	Measuring tape 	Socket wrench (10/16mm) 
	Hammer 	Cross Screwdriver 	Hammer drill 
Protection	ESD gloves 	Safety goggles 	Safety Shoes 



## 2.3 Installation Instructions

Minimum mounting distance requirement:

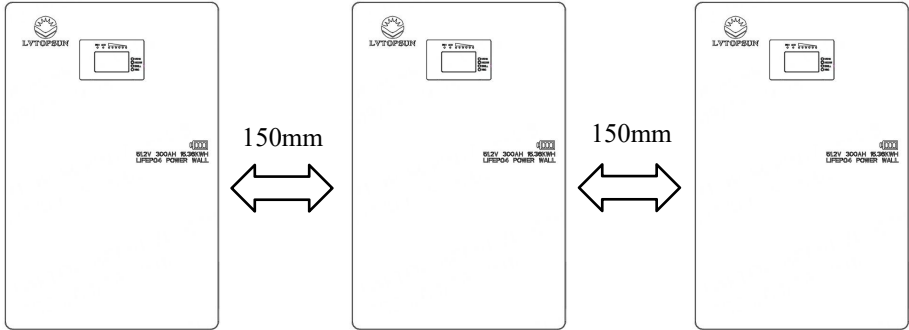

### 2.3.1 Installation Step

**Step 1** place LVTS-512300 on the floor, close to wall.

Determine hole position using marker.

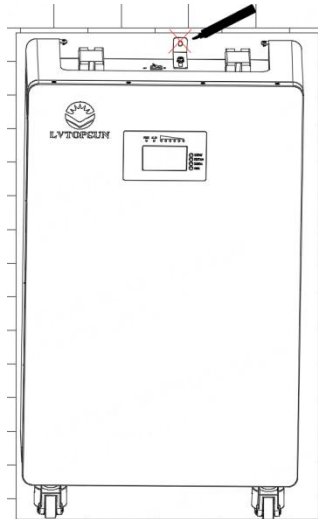



**Step 2** drill hole on the wall,  
fix wall connector using expansion bolt

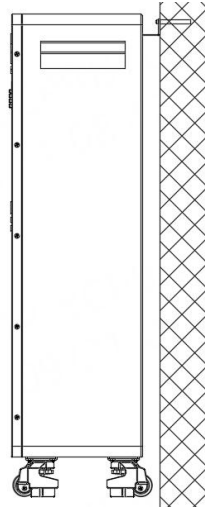

**Step3** Install rubber grommet.

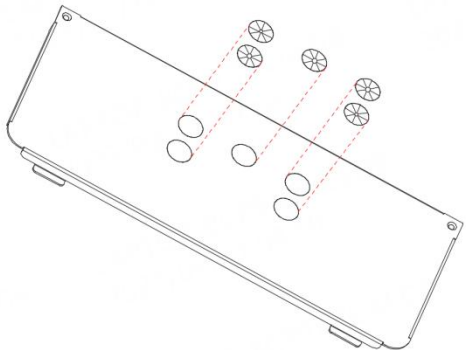
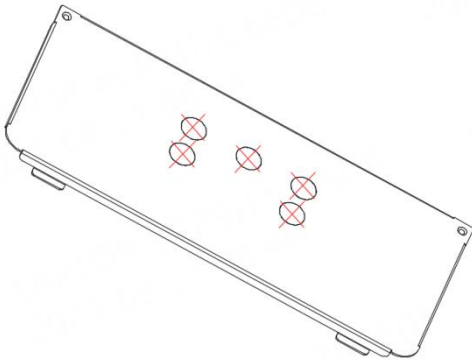



**Step4** Connect PE cable & power cable.

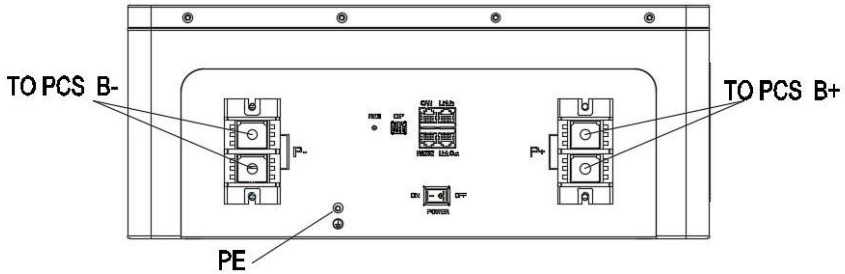

**Step 5** Connect communication cable. Wire all cables thru rubber grommet.

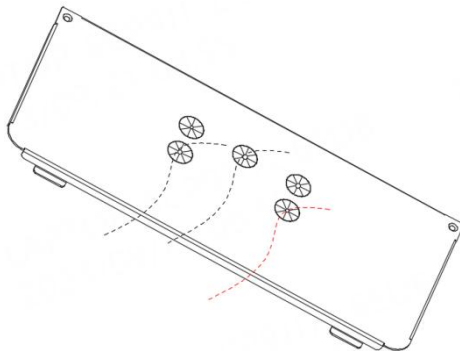
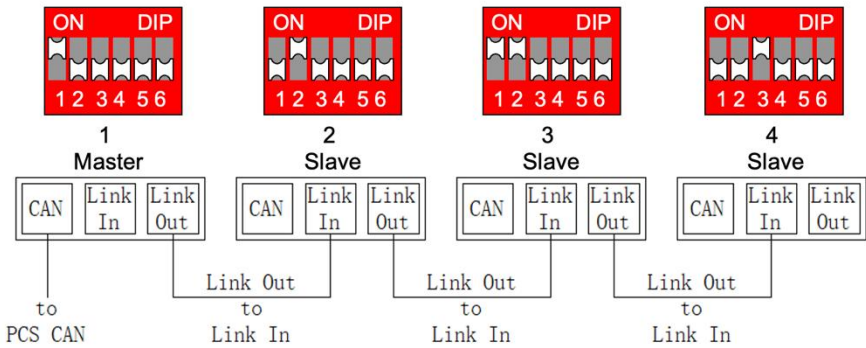



**Step 6** Refer to the following diagram when multiple batteries are connected in parallel:

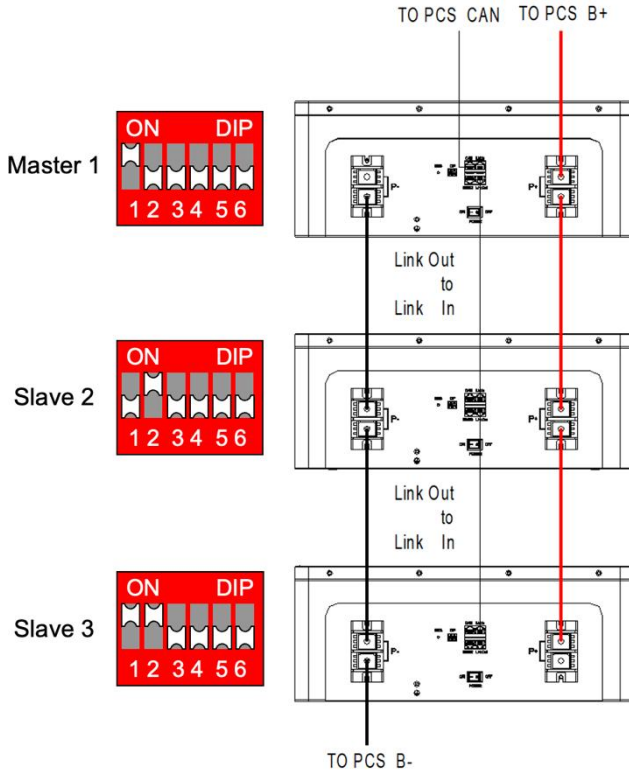

**Step 7** Install cover using cover bolts.

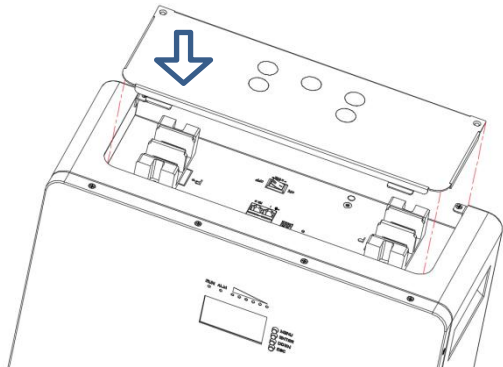

### 3 Technical Specifications

Basic Project		Parameter
Nominal Voltage		51.2V
Nominal Capacity		300Ah
Nominal Energy		15360Wh
Charge Voltage		56.16V
Charge Current		150A
Discharge Voltage Range		45.6V~56.16V
Discharge Current		200A
Communication Mode		CAN/RS485
Working Temperature	Charge	0℃~55℃
	Discharge	-20℃~55℃
Storage Temperature	Short Term (within 1 month)	-10℃~45℃
	Long Term (within 1 year)	0℃~35℃
Storage Humidity		<95% RH
Cell Type		LiFePO <sub>4</sub> , Lithium Iron Phosphate
Size		H780*W500*D230(mm)
Weight		120KG (Wall Bracket Included)
IP Level		IP21



## 4 Maintenance

### 4.1 Recharge Requirements During Storage

Batteries should be stored in temperature between  $-10^{\circ}\text{C} \sim +45^{\circ}\text{C}$ , and recharged regularly according to the following table with 0.2C (60A) current to 50% SOC after long time storage.

**Recharge requirement during storage**

Storage Temperature	Storage Relative Humidity	Storage Time	SOC
Below $-10^{\circ}\text{C}$	/	Not Allowed	/
$-10\sim 0^{\circ}\text{C}$	5%~70%	$\leq 1$ months	$30\% \leq \text{SOC} \leq 60\%$
$0\sim 25^{\circ}\text{C}$	5%~70%	$\leq 12$ months	$30\% \leq \text{SOC} \leq 60\%$
$25\sim 35^{\circ}\text{C}$	5%~70%	$\leq 6$ months	$30\% \leq \text{SOC} \leq 60\%$
$35\sim 45^{\circ}\text{C}$	5%~70%	$\leq 1$ months	$30\% \leq \text{SOC} \leq 60\%$
Above $45^{\circ}\text{C}$	/	Not Allowed	/

### 4.2 Recharge Requirements When Over Discharged

Please recharge over discharged (90% DOD) batteries according to the following table, otherwise over discharged battery will be damaged.

**Recharge requirement when battery is over discharged**

Storage Temperature	Storage Time	Note
$-10\sim 25^{\circ}\text{C}$	$\leq 15$ days	Battery disconnected from PCS
$25\sim 45^{\circ}\text{C}$	$\leq 7$ days	
$-10\sim 45^{\circ}\text{C}$	< 12 hours	Battery connected to PCS

**Attention: Disposal of batteries should follow local regulations.**