

USER MANUAL

LVTS-512300 LFP Battery



Contents

1 Product Overview	1
1.1 Appearance	1
1.2 Switch, LCD, LED & Communication Port	2
1.2.1 DIP Switch	2
1.2.2 Switch ON/OFF	3
1.2.3 Color touchscreen	3
1.2.4 Communication Port Definition	6
2 Installation Guide	7
2.1 Checking Deliverables	7
2.2 Tools	8
2.3 Installation Instructions	9
2.3.1 Installation Step	9
3 Technical Specifications	13
4 Maintenance	14
4.1 Recharge Requirements During Storage	14
4.2 Recharge Requirements When Over Discharged	14



1 Product Overview

LVTS-512300 is a 51.2V 300Ah Lithium battery that can be wall mounted or floor mounted.

Note: LVTS-512300 is **NOT** suitable for life-sustaining medical devices.

1.1 Appearance

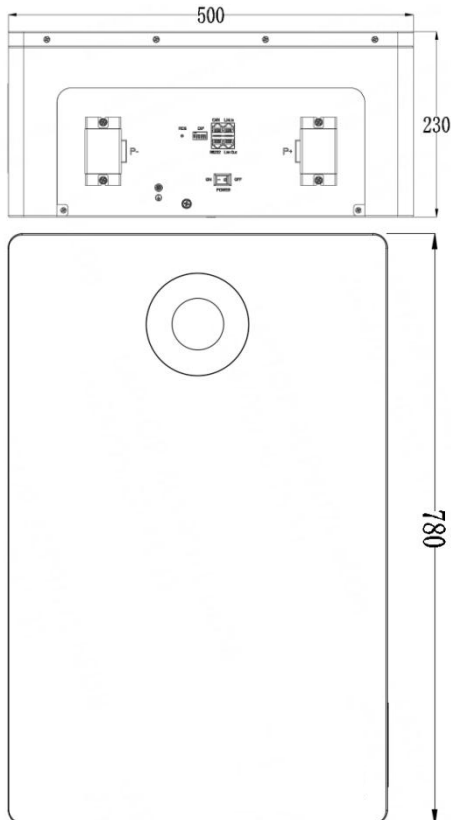



1.2 Switch, LCD, LED & Communication Port

1.2.1 DIP Switch

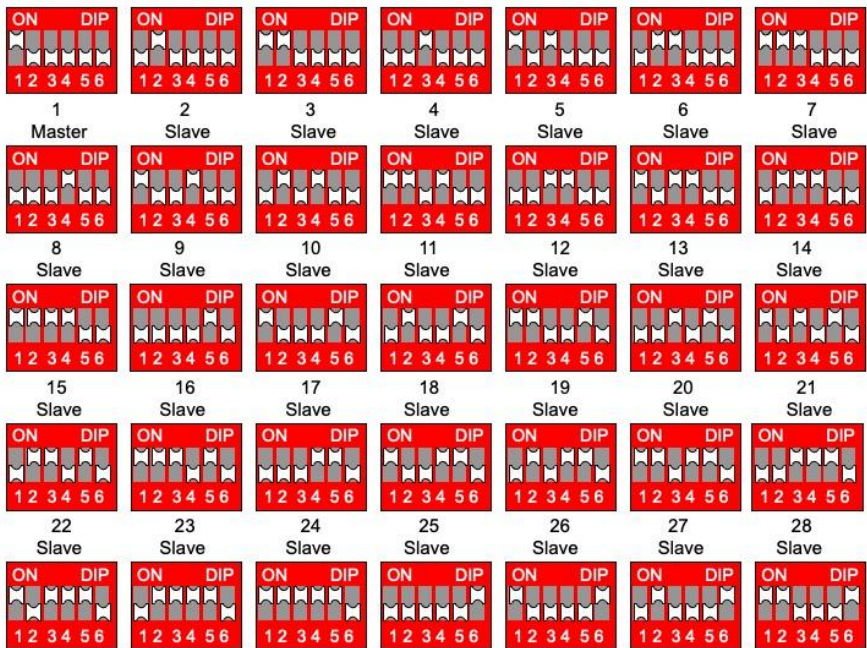

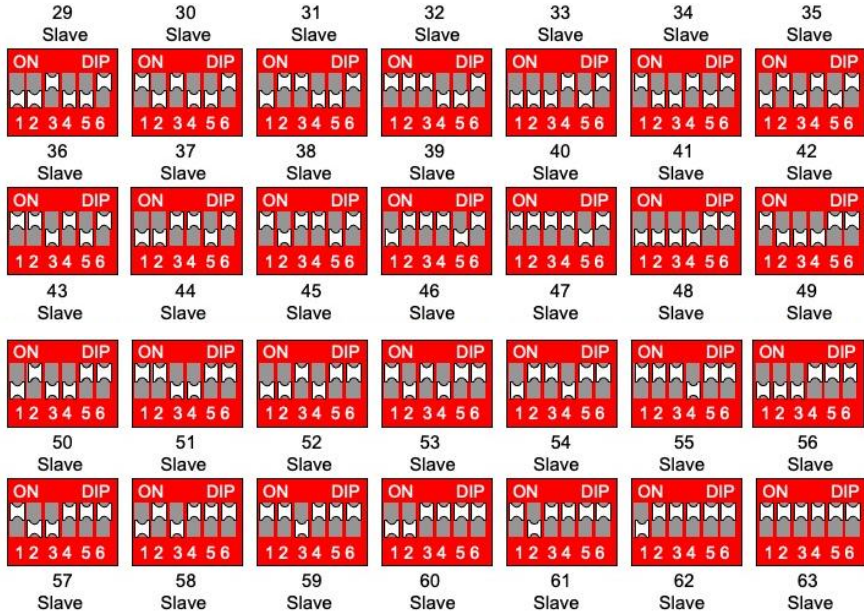

1.2.2 Switch ON/OFF

1、 Switch ON

For single LVTS-512300, set DIP switch to 1, then switch ON POWER button.

For multiple LVTS-512300 connected in parallel, set DIP switch according to 1.2.1, then switch ON POWER buttons of all batteries.

2、 Switch OFF

Switch OFF POWER button(s) of all batteries.

1.2.3 Color touchscreen



- 1) Swipe the screen to see “SN Info”, “Capacity Info”, “Temp Info”, “Cell Voltage”, “Current Event”, “History Event”, “Set Protocol” & “Display Time”.
- 2) If current protocol is incorrect, tap “CAN” checkbox and select correct protocol.
- 3) If current time is incorrect, tap “Set Time” button and change time then tap “Save” button.



SN Info

VER : P16S200A-41123-1.01G
 PACK: AS001007080424010001
 BMS : 315301540300781D

Capacity Info

Capacity: 200AH
 SOH: 100%
 SOC: 50%
 Cycle: 0

Temp Info

T1: 25.0 °C T3: 25.0 °C
 T2: 25.0 °C T4: 25.0 °C
 T_MOS: 25.0 °C
 T_ENV: 25.0 °C

Cell Volatge

01: 3200mV	09: 3200mV
02: 3200mV	10: 3200mV
03: 3200mV	11: 3200mV
04: 3200mV	12: 3200mV
05: 3200mV	13: 3200mV
06: 3200mV	14: 3200mV
07: 3200mV	15: 3200mV
08: 3200mV	16: 3200mV

51.2V 0A



Current Event

Alarm: None
Protect:None
Fault:None

History Event

001 04.29 12:00 pOVW



Set Protocol

PYLON CAN

RS485

Set Protocol

01:PYLON

02:GROWATT

03:VICTRON

04:SMA

05:MUST

06:SO FAR

Display Time

2024 - 4 - 29 12:00

Set Time

Set Time

2024 - 4 - 29 12:00

Save

Cancel

1.2.4 Communication Port Definition

1.2.4.1 CAN/RS485 to PCS

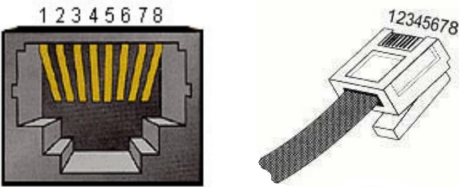
Port definitions	RJ45 Pin	Function
	1	RS485-B
	2	RS485-A
	3	GND
	4	CAN-H
	5	CAN-L
	6	NC
	7	RS485-A
	8	RS485-B





1.2.4.2 RS232 to PC

Port definitions	RJ45 Pin	Function
	1	RS232-TX
	2	GND
	3	RS232-RX
	4	NC
	5	NC
	6	NC
	7	NC
	8	NC

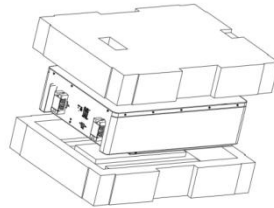
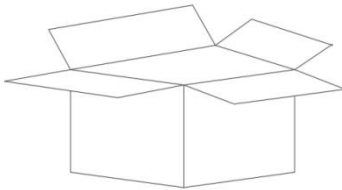

2 Installation Guide

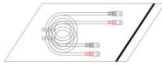
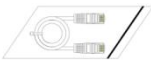
2.1 Checking Deliverables









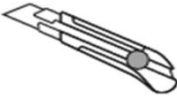

NO.	Pictures	Quantity	Description
1		1 pc	Battery
2		1 pc	cover
3		2 pcs	Cover bolt
4		1 pair	Power cable
5		1 pc	Comm cable
6		1 pc	Manual

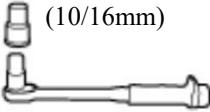

7		5 pc	Rubber Grommet
8		1 pc	Expansion Bolt
9		1 pc	Wall Connector

2.2 Tools

Tools			
Installation	Knife 	Measuring tape 	Socket wrench (10/16mm) 
	Hammer 	Cross Screwdriver 	Hammer drill 
Protection	ESD gloves 	Safety goggles 	Safety Shoes 

2.3 Installation Instructions

Minimum mounting distance requirement: (Wall Mounted)

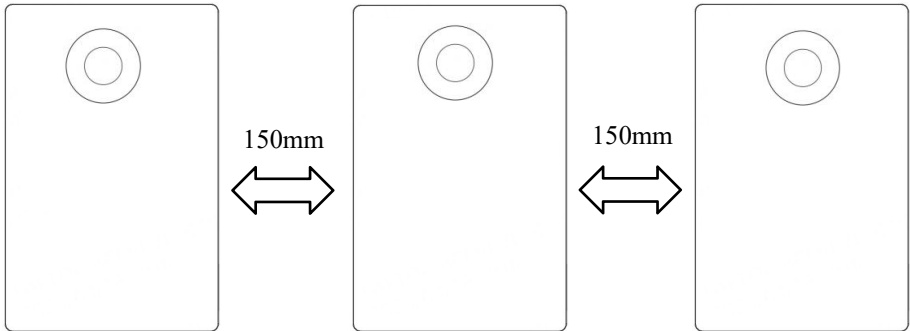

2.3.1 Installation Step

Step 1 place LVTS-512300 on the floor, close to wall.
Determine hole position using marker.

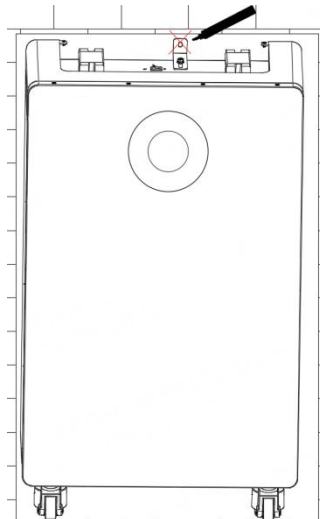



Step 2 drill hole on the wall,
fix wall connector using expansion bolt

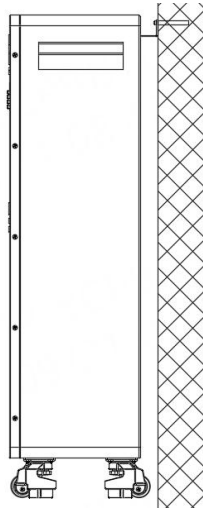

Step3 Install rubber grommet.

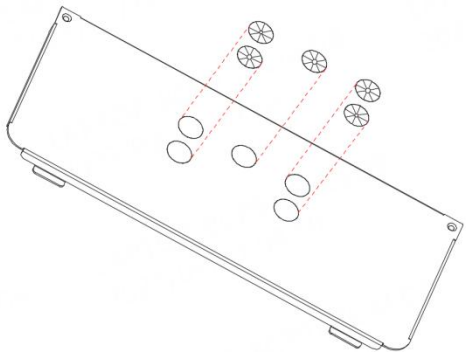
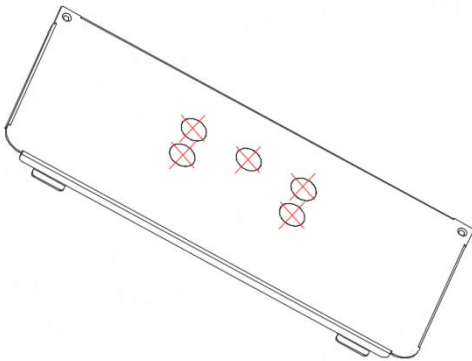

Step4 Connect PE cable & power cable.

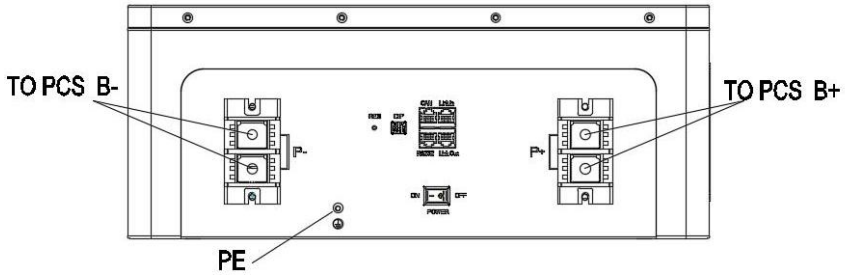

Step 5 Connect communication cable. Wire all cables thru rubber grommet.

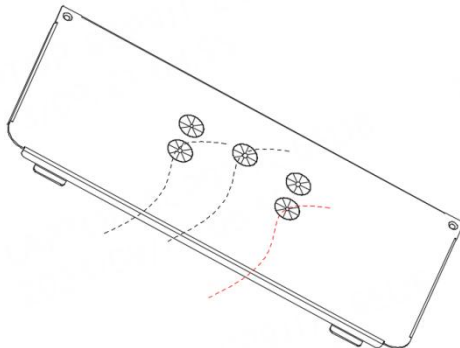
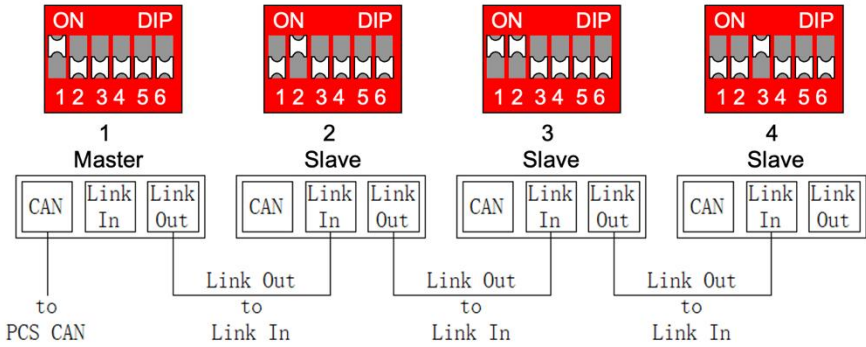

Step 6 Refer to the following diagram when multiple batteries are connected in parallel:

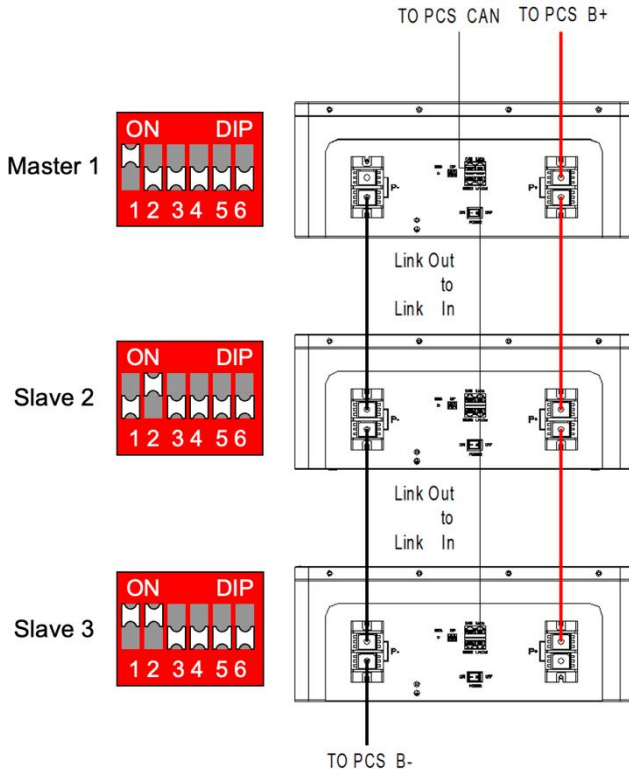

Step 7 Install cover using cover bolts.

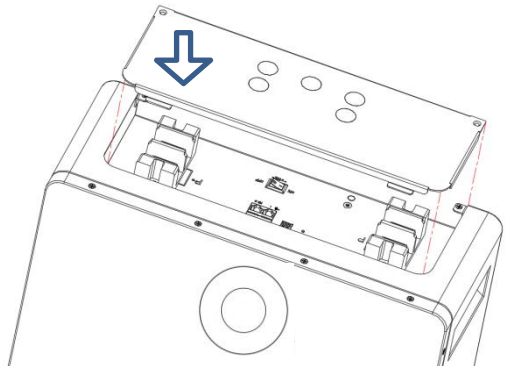



3 Technical Specifications

Basic Project		Parameter
Nominal Voltage		51.2V
Nominal Capacity		300Ah
Nominal Energy		15360Wh
Charge Voltage		56.16V
Charge Current		150A
Discharge Voltage Range		45.6V~56.16V
Discharge Current		200A
Communication Mode		CAN/RS485
Working Temperature	Charge	0°C ~ 55°C
	Discharge	-20°C ~ 55°C
Storage Temperature	Short Term (within 1 month)	-10°C ~ 45°C
	Long Term (within 1 year)	0°C ~ 35°C
Storage Humidity		<95% RH
Cell Type		LiFePO ₄ , Lithium Iron Phosphate
Size		H780*W500*D230(mm)
Weight		120KG (Wall Bracket Included)
IP Level		IP21

4 Maintenance

4.1 Recharge Requirements During Storage

Batteries should be stored in temperature between $-10^{\circ}\text{C} \sim +45^{\circ}\text{C}$, and recharged regularly according to the following table with 0.2C (60A) current to 50% SOC after long time storage.

Recharge requirement during storage

Storage Temperature	Storage Relative Humidity	Storage Time	SOC
Below -10°C	/	Not Allowed	/
$-10\sim 0^{\circ}\text{C}$	5%~70%	≤ 1 months	$30\% \leq \text{SOC} \leq 60\%$
$0\sim 25^{\circ}\text{C}$	5%~70%	≤ 12 months	$30\% \leq \text{SOC} \leq 60\%$
$25\sim 35^{\circ}\text{C}$	5%~70%	≤ 6 months	$30\% \leq \text{SOC} \leq 60\%$
$35\sim 45^{\circ}\text{C}$	5%~70%	≤ 1 months	$30\% \leq \text{SOC} \leq 60\%$
Above 45°C	/	Not Allowed	/

4.2 Recharge Requirements When Over Discharged

Please recharge over discharged (90% DOD) batteries according to the following table, otherwise over discharged battery will be damaged.

Recharge requirement when battery is over discharged

Storage Temperature	Storage Time	Note
$-10\sim 25^{\circ}\text{C}$	≤ 15 days	Battery disconnected from PCS
$25\sim 45^{\circ}\text{C}$	≤ 7 days	
$-10\sim 45^{\circ}\text{C}$	< 12 hours	Battery connected to PCS

Attention: Disposal of batteries should follow local regulations.